

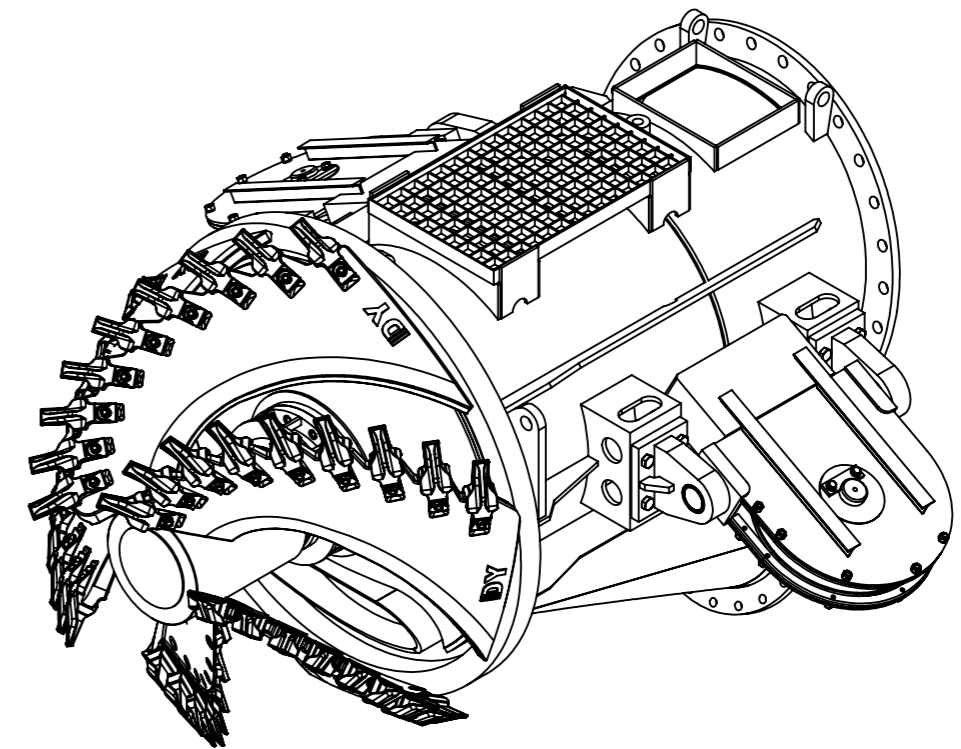

LADDER PIPE FLANGE:  
 DN1000  
 28 x Ø36 HOLE AT P.C.D. 1160

SUCTION MOUTH FLANGE:  
 DN500  
 20 x Ø26 HOLE AT P.C.D. 620

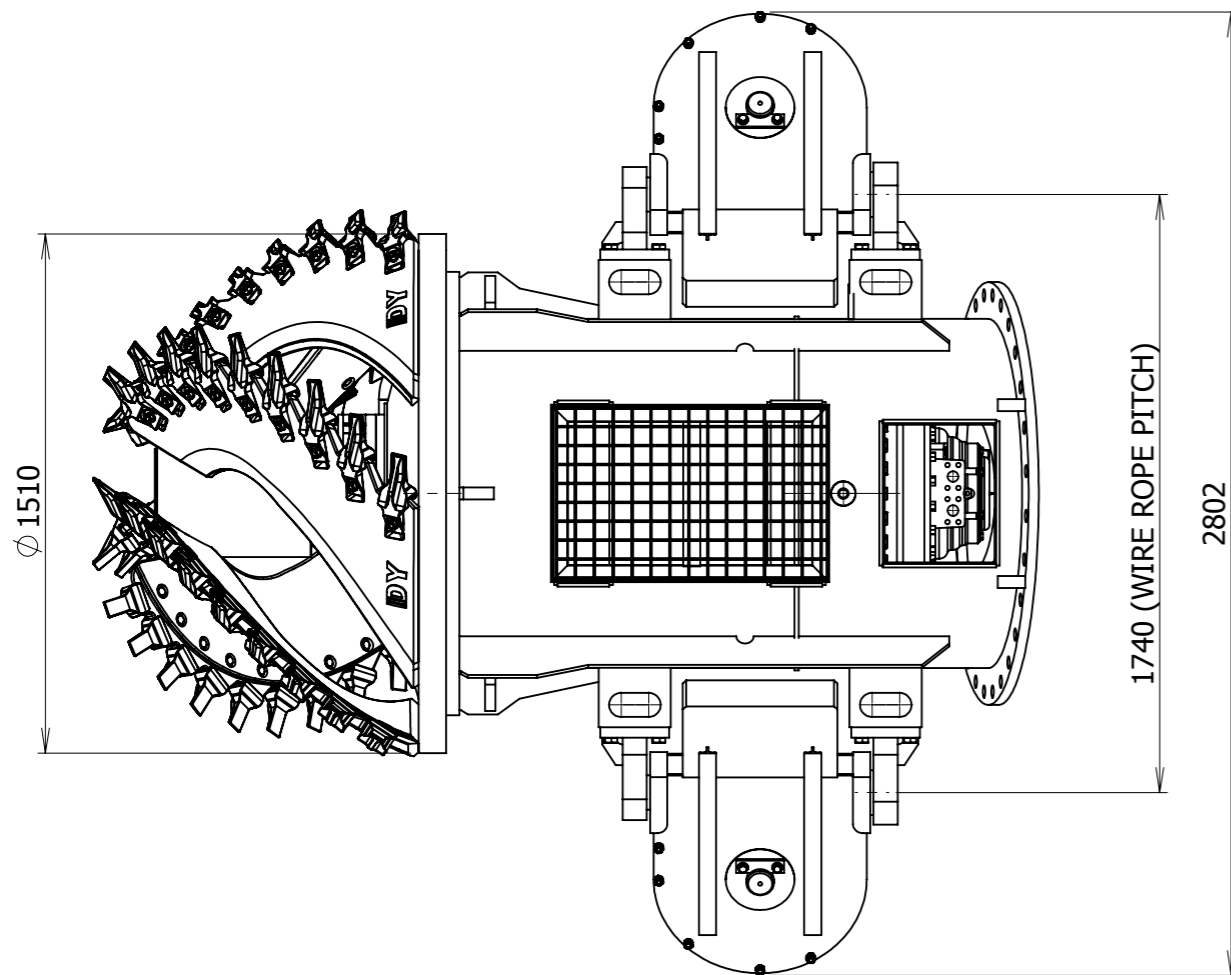

NOTE:  
 ALL DIMENSIONS ARE IN MILLIMETERS

DRAWN BY: MS	CSD500 CUTTER FRONT PART		 www.dredgeyard.com
CHECKED BY: TDL	GENERAL ARRANGEMENT		
APPROVED BY: BY	WEIGHT: N/A	DATE: 4-OCT-2015	DWG. NO.: CF-500-000
SCALE: NTS	A3	THIRD ANGLE PROJECTION 